

Steamfast™

MODEL

SF-623



MID-SIZE FABRIC STEAM PRESS

OWNER'S GUIDE

IMPORTANT SAFETY INSTRUCTIONS

This owner's guide and any additional inserts are considered part of the product. They contain important information about safety, use, and disposal. Before using the product, please familiarize yourself with all operating and safety instructions. Please keep all documents for future reference and pass these documents on, together with the product, to any future owner. See our website for the most current version of this owner's guide.

INTENDED USE: This product is intended to be used indoors for the steaming of garments and other fabrics in the United States and/or Canada. This product is not intended for commercial or industrial uses. The manufacturer assumes no responsibility for damage or injury due to unauthorized use or product modification. Failure to follow these directions will void the product warranty.

WARNING: Risk to Children and Impaired Persons Supervision is required during the installation, operation, cleaning and maintenance of this product by children under age 12 and anyone with reduced physical, sensory or mental capabilities. Children should be supervised to ensure that they do not play with the appliance, its parts and packaging material.

Directions to reduce risk of fire, electrical shock, and injury:

1. Read all instructions before use.
2. Use caution when handling this steam unit. Burns could occur from touching hot metal parts, hot water, or steam. Use special care to avoid contact with hot water when turning the product upside down to empty the reservoir.
3. To reduce the risk of contact with hot water, test whether steam is ready before each use while carefully holding the product away from your body. If no steam appears, wait a few more minutes and test again. Do not look into the appliance, use your hands or other objects to check for steam.
4. Do not leave appliance unattended while connected.
5. To reduce the risk of electric shock, do not immerse the appliance in water or other liquids.
6. Always disconnect appliance from electrical outlet when filling with water or emptying, and when not in use.
7. Do not allow cord to touch hot surfaces. Let appliance cool completely before putting away. Loop cord loosely around appliance when storing.
8. Never yank cord to disconnect from outlet. Instead, grasp just the plug and pull to disconnect.
9. Do not operate appliance with a damaged cord, or if the appliance has been dropped or damaged. To reduce the risk of electric shock, do not disassemble or attempt to repair the appliance. All repairs must be performed by a qualified service professional. Incorrect reassembly or repair could cause a risk of fire, electric shock, or injury when the appliance is used.
10. A loose fit between wall outlet (receptacle) and plug may cause overheating and distortion of the plug. Discontinue use of the product in this outlet. Contact a qualified electrician to replace loose or worn outlets.
11. To reduce the likelihood of circuit overload, do not operate another high wattage appliance on the same circuit.
12. If an extension cord is absolutely necessary, a 15 amp rated cord should be used. Cords

rated for less amperage may overheat. Care should be taken to arrange the cord so that the cord cannot be pulled or tripped over.

13. This GARMENT STEAMER is for use with a 120 volt electrical outlet. The cord has a plug as shown at A in Figure 65.1. An adapter, as shown at C, can be used to connect three-blade grounding-type plugs to two-slot receptacles (it is not included with your product). The green grounding lug extending from the adapter must be connected to a permanent ground such as a properly grounded outlet box. An adapter should not be used if a three-slot grounded receptacle is available. *NOTE: A TWO-PRONG ADAPTOR IS NOT INCLUDED WITH THIS PRODUCT.

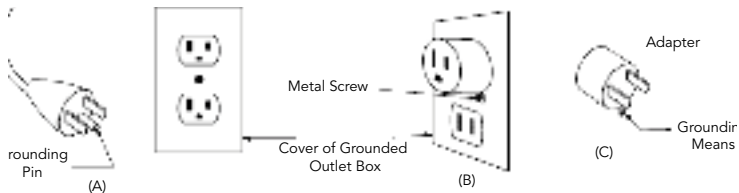

Figure 65.1

WARNING: Changes or modifications to this unit not expressly approved by the party responsible for compliance could void the user's authority to operate the equipment.

FCC CONSUMER ADVISEMENT: This equipment may generate, use and/or radiate radio frequency energy that may cause harmful interference to radio communications. If this equipment does cause harmful interference to radio or television reception, which can be determined by turning the equipment off and on, the user is encouraged to contact Steamfast Consumer Service at 1-800-711-6617.

SAVE THESE INSTRUCTIONS

Questions or comments?

- steamfast.com
- consumerservice@steamfast.com
- 1-800-711-6617

Speak your mind! We invite you to review this product online:
steamfast.com/reviews

The following features and accessories are included with your steam press. Carefully inspect packaging material as some parts are shipped inside Styrofoam packaging. To obtain possible missing parts, refer to the Consumer Support section on page 10 of this manual.

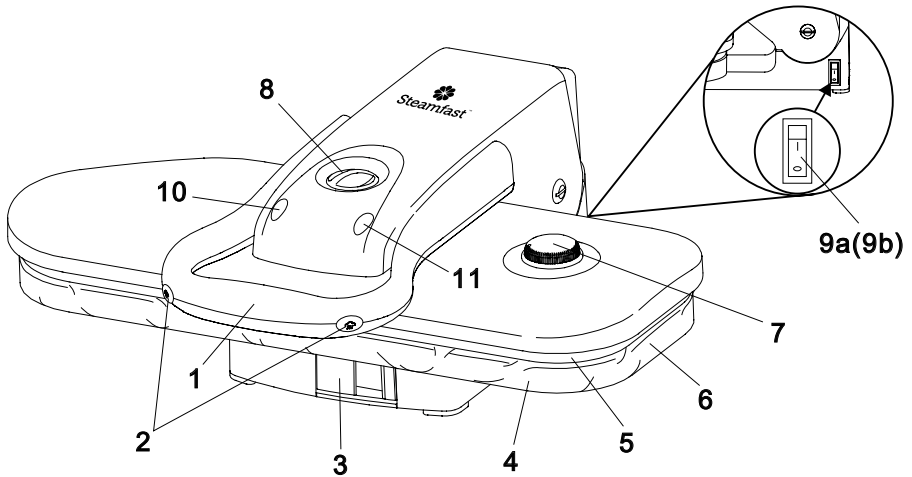

UNIT FEATURES & ACCESSORIES

- 1 Handle
- 2 Steam Burst Buttons
- 3 Water Reservoir
- 4 Ironing Board
- 5 Pressing Plate
- 6 Ironing Board Cover
- 7 Temperature Control Dial
- 8 Locking Knob
- 9A On/Off Switch
- 9B Power Indicator Light (Red)
- 10 Pressing Indicator Light
- 11 Steam Burst Ready Indicator Light
- 12 Measuring Cup
- 13 Spray Bottle
- 14 Pressing Cushion

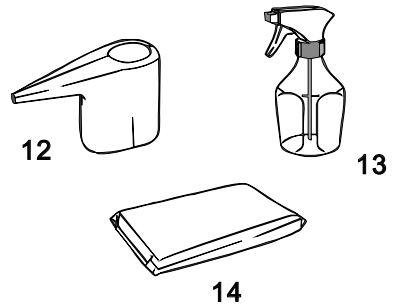

-
- The Handle (1) is used to safely lift up and lower the Pressing Plate, and carry the unit.
 - The Steam Burst Buttons (2) are located on either side of the Handle, and produce a powerful burst of steam when pressed.
 - The Water Reservoir (3) is the tank in which water is stored for use by the unit. There must be water in the Water Reservoir in order for the unit's steam burst function to work correctly.
 - The Ironing Board (4) is the padded surface onto which fabric is placed during pressing.
 - The Pressing Plate (5) is the large temperature-controlled surface that heats and presses fabric.
 - The Ironing Board Cover (6) is the durable cover that protects the Ironing Board. The fabric cover is removable and can be washed.
 - The Temperature Control Dial (7) is used to select a desired temperature, by turning it to the fabric setting that matches the material that you are pressing.
 - The Locking Knob (8) locks the Pressing Plate and Ironing Board together. This allows for carrying and storage of the unit.
 - The On/Off Switch (9a) activates and deactivates the unit.
 - The Power Indicator Light (Red) (9b) illuminates when the On/Off Switch is set to the "On" (I) position, providing you with a clear visual indication that the unit is powered on.
 - The Pressing Indicator Light (Orange) (10) illuminates while the unit is heating to the selected temperature. When deactivated, this indicates that you are ready to press.
 - The Steam Burst Ready Indicator Light (Orange) (11) illuminates once the unit is ready to produce bursts of steam, providing you with a clear visual indication that you can begin using the Steam Burst Buttons.
 - The Measuring Cup (12) is designed to assist you in easily filling the Water Reservoir with distilled water.
 - The Spray Bottle (13) allows you to moisten fabrics before pressing, which helps to make the pressing process easier and more effective in certain instances.
 - The Pressing Cushion (14) is a fabric-covered pad used for pressing gathered or contoured areas such as sleeves, darts, or collars.

FILLING WATER RESERVOIR

1. Place Mid-Size Fabric Steam Press on a flat, level surface.
2. Turn Locking Knob to "Unlock" position to unlock Pressing Plate.
3. Lift up Pressing Plate using Handle. It will automatically stay in lifted position.
4. Pull Water Reservoir out. Note that Water Reservoir cannot be completely removed from unit; do not attempt to force it free.
5. Using Measuring Cup (included), fill Water Reservoir up to the 150ml (5.07 oz) line with water.

OPERATION

1. With Pressing Plate in lifted position, plug power cord into electrical outlet, and set On/Off Switch to "On" (I) position (FIGURE 1).
2. Identify type of fabric you are going to press, and select corresponding temperature setting using Temperature Control Dial. Note that it is best to start with the most delicate fabrics first, as higher levels of heat will cause damage to Nylon and Silk. Pressing Indicator Light will illuminate.
3. A few minutes of heating time will be required to reach selected temperature. Once Pressing Plate is heated, Pressing Indicator Light will deactivate. You are now ready to begin pressing.
4. Lay fabric flat on Ironing Board.
5. If pressing wool, cotton or linen you may choose to spray with a burst of steam. This function is available once Steam Burst Ready Indicator Light illuminates.

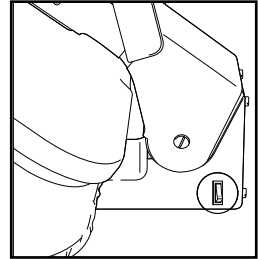

FIGURE 1

NOTE: Do not activate burst of steam with unit completely closed, as this may damage unit. Best results are obtained if Pressing Plate is held open approximately 3 in. (75 mm.) above Ironing Board before pressing Steam Burst Button. For safety reasons, do not hold Pressing Plate open more than 3 in. (75 mm.) when using steam burst function. Only use burst of steam for 2-3 seconds for best results. If press is left on fabric for more than 10 seconds, it could result in damage to the fabric.

NOTE: When using the nylon or silk settings, no steam is produced.

6. To press, lower Pressing Plate gently onto fabric and Ironing Board. Hold there for 8-10 seconds, then lift up Pressing Plate. Repeat until you have achieved desired crease and smoothness. See page 7 of this manual for more specific pressing tips.
7. Once pressing tasks are complete, immediately set On/Off Switch to "Off" (O) position and unplug power cord from electrical outlet. Refer to page 8 of this manual for further information about cleaning and storage of Mid-Size Fabric Steam Press.

STEAM BURST

1. Hold Pressing Plate approximately 3 in. (75 mm.) above Ironing Board.
2. Press Steam Burst Button to release a burst of steam onto fabric for 2-3 seconds.
3. Lower Pressing Plate onto fabric for 8-10 seconds, then raise once again. **Note: If press is left on fabric for more than 10 seconds, it could result in damage to fabric.**
4. Repeat steps 1-3 above until fabric is smooth and wrinkle-free.

PRESSING AND STEAMING TIPS

Pressing Shirts And Blouses

1. Place shoulder yoke on Ironing Board first and press.
2. Next, place sleeves onto Ironing Board with fold parallel to long seam and press.
3. Place cuffs onto end of Ironing Board and press.
4. Place bottom of shirt behind Ironing Board. Begin by pressing the side with pocket. Pull shirt towards you as you press each section.
5. Finish by pressing collar of shirt.

Pressing Pants

1. Place Pressing Cushion under waistband and press, repositioning waistband until completely pressed.
2. To press inseam, place Pressing Cushion under area to be pressed.
3. Place pleated area on Ironing Board. Carefully fold pleats and press.

Other Techniques

- Placing Pressing Cushion between fabric and Pressing Plate may help with delicate fabrics.
- If you have older types of buttons or zippers, you may need to take special care to avoid melting. In order to do so, place garment face-down and cover with Pressing Cushion before pressing.
- Spray Bottle may be used to spray fabrics lightly. This will further help to remove exceptionally stubborn wrinkles.
- Place a damp cloth over fabric before pressing, which will help with stubborn wrinkles or heavy gauge fabrics.
- To press large pieces of fabric, place entire piece behind Ironing Board. Pull fabric towards you, over Ironing Board, and lower Pressing Plate. Press fabric in sections until completed.
- Embroidery should be placed face down on Ironing Board to reduce wear and prevent damage to delicate areas.

AUTO SHUT-OFF

The Auto Shut-Off feature deactivates electrical power to the heater when the Pressing Plate has been left in closed position against the Ironing Board. The Pressing Indicator Light (Orange) and Steam Burst Ready Indicator Light (Orange) does not illuminate. Heater functionality is restored when the Pressing Plate is lifted back up.

IMPORTANT: Auto Shut-Off does not mean that power to the unit is totally cut off. Power is always on, and the Power Indicator Light will remain illuminated until On/Off Switch is set to "Off" (O) position (FIGURE 1, page 6).

CLEANING THE MID-SIZE FABRIC STEAM PRESS

1. Fill Water Reservoir with water using procedure on page 6 of this manual.
2. Place Pressing Cushion in the middle of Ironing Board.
3. Place a clean towel over Pressing Cushion and Ironing Board.
4. Set Temperature Control Dial to the highest setting (LINEN).
5. When Steam Burst Ready Indicator Light illuminates, lower Pressing Plate onto Pressing Cushion.
6. Press Steam Burst Button six times.
7. Allow Pressing Plate to cool.
8. Clean Pressing Plate with damp cloth. Do not use abrasive materials, as this may damage Pressing Plate.
9. Ironing Board Cover is removable for cleaning. Hand wash only with mild detergent.

PROPER STORAGE

1. Once pressing is complete, immediately turn unit off and unplug power cord from electrical outlet.
2. Allow unit to cool completely (at least 30 minutes).
3. Lower Pressing Plate down, and turn Locking Knob to "Lock" position.
4. Store all accessories safely away, preferably near Mid-Size Fabric Steam Press.
5. Store Mid-Size Fabric Steam Press in a cool, dry place.

PROBLEM	POSSIBLE CAUSE	SOLUTION
Unit fails to heat up and steam. Power Indicator Light does not illuminate.	Unit is not plugged in.	Plug into electrical outlet.
	Household Circuit Breaker/ Ground Fault Interrupter has tripped or blown a fuse.	Reset Circuit Breaker/ Ground Fault Interrupter, or replace fuse. If you need assistance, contact a licensed electrician.
Unit fails to heat up and steam. Power Indicator Light does illuminate.	Auto Shut-Off has engaged.	Refer to Auto Shut-Off section on page 8 of this manual for proper procedure.
	Water Reservoir is empty.	Refill Water Reservoir using procedures on page 6 of this manual.
	Unit is damaged or malfunctioning.	Immediately cease usage and contact our Customer Support Department.
Steam Burst output is weak or intermittent.	Pressing Plate needs to be cleaned.	Refer to Cleaning the Fabric Steam Press section on page 8 of this manual for proper procedure.

CONSUMER SERVICES

For problems with your Fabric Steam Press, please refer to the troubleshooting guide located on Page 9 of this manual. Additional inquiries should be directed to our consumer support services through our Web site, www.steamfast.com.

If you do not have internet access, you may also contact our Consumer Service Department by telephone, at **1-800-711-6617**.

NOTE: In order for our Consumer Service representatives to help you as quickly and efficiently as possible, please have the following information ready before calling:

- Purchase information (where and when you purchased this product)
- Copy of purchase receipt / proof of purchase
- Product serial number (located on electrical specification label on back of unit)

For information regarding your 1 year limited warranty, refer to Page 12 of this manual.

PRODUCT SPECIFICATIONS

MODEL	SF-623
VOLTAGE	120V
WATTAGE	1500W
AMPERAGE	12.5A
WATER CAPACITY	5.07 OZ. (150 ML.)
UNIT WEIGHT	12.79 LBS. (5.80 KG.)
UNIT DIMENSIONS	20.47" (52 CM.) x 17.16" (43.6 CM.) x 6.73" (17.1 CM.)
POWER CORD LENGTH	6.6' (201.0 CM.)

ACCESSORIES & PARTS

When ordering accessories and parts for your Fabric Steam Press, you may refer to the part numbers below. Replacement parts may be ordered through our Web site:

www.steamfast.com

You may also contact Consumer Service directly:

consumerservice@steamfast.com or **1-800-711-6617**

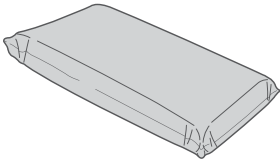

PRESSING CUSHION
A660-003



SPRAY BOTTLE
A660-005

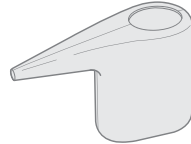

**FUNNEL
CUP**
A660-006

2-YEAR LIMITED WARRANTY

What is covered

Steamfast, a division of Vornado Air, LLC (“Steamfast”). Subject to the terms and conditions of this 2-Year Limited Warranty (“Warranty”) as set forth below, Steamfast warrants to the original consumer or purchaser (“Buyer”) that this Steamfast®-branded steam product, excluding all accessories and attachments, (the “Product”) is to be free from defects in material and workmanship for a period of 2 years from the date of purchase when used and maintained in accordance with the Owner’s Guide (the “Warranty Period”). In the event Buyer notifies Steamfast of a defect in the Product within the Warranty Period, Steamfast will replace the Product and/ or defective component parts, as applicable and necessary. Any such replacement will be made at no charge to Buyer for parts or labor, provided that Buyer shall be responsible for all shipping and transportation costs associated with returning the Product to Steamfast for inspection and covered replacement.

What is not covered

This Warranty shall not be applicable to damage or loss caused in whole or in part by:

- Repairs, modifications or alterations to the Product by anyone other than Steamfast.
- Use or operation of the Product outside the permitted or intended uses described by Steamfast in the Owner’s Guide, or other careless operation, handling, misuse, or abuse of the Product.
- Lack of proper maintenance or timely cleaning of the Product as specified in the Owner’s Guide.
- Use of the Product other than for normal household purposes.
- Normal wear and tear.
- Used consumable parts, accessories and attachments, including, but not limited to, brushes, hangers, scrub pads and mop pads.
- Use of parts and accessories other than those produced or recommended by Steamfast.
- Cosmetic damage, such as scratches, nicks and dents.
- Damage caused by accident, water, flood, fire or other acts of nature or external causes.

Warranty limitations and exclusions

- NO OTHER EXPRESS WARRANTY IS GIVEN BY STEAMFAST TO BUYER AND NO REPRESENTATIVE HAS THE AUTHORITY TO MAKE REPRESENTATIONS OTHER THAN THOSE PROVIDED HEREIN.
- THERE ARE NO WARRANTIES WHICH EXTEND BEYOND THE DESCRIPTION ON THE FACE HEREOF AND ALL IMPLIED WARRANTIES, SPECIFICALLY THE IMPLIED WARRANTIES OF MERCHANTABILITY AND FITNESS FOR A PARTICULAR PURPOSE, ARE HEREBY EXPRESSLY LIMITED TO THE DURATION OF THE WARRANTY PERIOD, UNLESS A SHORTER PERIOD IS PERMITTED BY LAW.
- STEAMFAST’S REPLACEMENT OF THE PRODUCT IS THE EXCLUSIVE REMEDY. UNDER NO CIRCUMSTANCES SHALL STEAMFAST BE LIABLE TO BUYER OR ANY OTHER PERSON FOR ANY INCIDENTAL, SPECIAL, CONSEQUENTIAL, OR OTHER DAMAGES, EVEN IF STEAMFAST HAS BEEN ADVISED OF OR COULD REASONABLY FORESEE THE POSSIBILITY OF SUCH DAMAGES, INCLUDING, BUT NOT LIMITED TO, LOSS OF PROFITS OR DAMAGE, WHETHER ARISING OUT OF BREACH OF WARRANTY, BREACH OF CONTRACT OR UNDER ANY OTHER

THEORY OF LAW.

- THIS WARRANTY GIVES BUYER SPECIFIC LEGAL RIGHTS. BUYER MAY ALSO HAVE OTHER RIGHTS WHICH VARY FROM STATE-TO-STATE. SOME STATES DO NOT ALLOW THE EXCLUSION OR LIMITATION OF INCIDENTAL OR CONSEQUENTIAL DAMAGES, AND SOME STATES DO NOT ALLOW LIMITATIONS ON HOW LONG AN IMPLIED WARRANTY LASTS, SO THE ABOVE LIMITATION OR EXCLUSION MAY NOT APPLY TO BUYER.

How do you register the Warranty

Buyer must complete an application to register this Warranty within sixty (60) days following date of purchase. Buyer may either visit Steamfast's website at steamfast.com and complete an online application or mail a completed application to Steamfast. Failure to register this Warranty within sixty (60) days following date of purchase will render this Warranty null and void.

Warranty service

For warranty service, call 1-800-711-6617 or email consumerservice@steamfast.com to obtain a Return Authorization ("RA") form. Include the Product model number and serial number, as well as Buyer's name, address, city, state, zip code and phone number when contacting Steamfast for warranty service. Buyer may be required to provide the original sales receipt for purposes of verifying date of purchase. After receiving the RA form, the Product must be shipped, postage prepaid by Buyer, to:

Steamfast
Attn: Warranty & Repair
415 E. 13th Street
Andover, KS 67002

To assure proper handling, packages must be clearly marked with the RA number. Packages not clearly marked with the RA number may be refused at the receiving dock.

Important: After receiving return authorization, carefully pack the Product to avoid damage in shipping. Damage in shipping is not covered by the Warranty and shall be the sole responsibility of Buyer. Damage or loss not covered by this Warranty or occurring outside the Warranty Period will require a fee to cover the cost of handling and shipping. All such fees and costs shall be the sole responsibility of Buyer.

Please allow at least 1-2 weeks for return of the Product after it is received by Steamfast. For ease of recordkeeping, it is recommended that Buyer staple or attached the original sales receipt to this Owner's Guide and record the Product serial number (located on the Product specifications decal) here:

© 2018 Vornado Air, LLC • Andover, KS 67002

Specifications subject to change without notice.

Steamfast® is a trademark owned by Vornado Air, LLC.

Manufactured in China.

Steamfast Consumer Service

W: steamfast.com • P: 1-800-711-6617 • E: consumerservice@steamfast.com

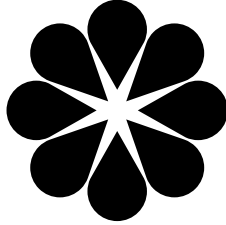

SteamfastTM

Steamfast

415 East 13th, Andover, KS 67002

1-800-711-6617 | steamfast.com | consumerservice@steamfast.com