

Steamfast™

MODEL

SF-565



PROFESSIONAL FABRIC STEAMER

OWNER'S GUIDE

IMPORTANT SAFETY INSTRUCTIONS

This owner's guide and any additional inserts are considered part of the product. They contain important information about safety, use, and disposal. Before using the product, please familiarize yourself with all operating and safety instructions. Please keep all documents for future reference and pass these documents on, together with the product, to any future owner. See our website for the most current version of this owner's guide.

INTENDED USE: *This product is intended to be used indoors for the steaming of garments and other fabrics in the United States and/or Canada. This product is not intended for commercial or industrial uses. The manufacturer assumes no responsibility for damage or injury due to unauthorized use or product modification. Failure to follow these directions will void the product warranty.*

WARNING: *Risk to Children and Impaired Persons. Supervision is required during the installation, operation, cleaning and maintenance of this product by children under age 12 and anyone with reduced physical, sensory or mental capabilities. Children should be supervised to ensure that they do not play with the appliance, its parts and packaging material.*

Directions to reduce risk of fire, electrical shock, and injury:

- 1. Read all instructions before use.*
- 2. Use caution when handling this steam unit. Burns could occur from touching hot metal parts, hot water, or steam. Use special care to avoid contact with hot water when turning the product upside down to empty the reservoir.*
- 3. To reduce the risk of contact with hot water, test whether steam is ready before each use while carefully holding the product away from your body. If no steam appears, wait a few more minutes and test again. Do not look into the appliance, use your hands or other objects to check for steam.*
- 4. Do not leave appliance unattended while connected.*
- 5. To reduce the risk of electric shock, do not immerse the appliance in water or other liquids.*
- 6. Always disconnect appliance from electrical outlet when filling with water or emptying, and when not in use.*
- 7. Do not allow cord to touch hot surfaces. Let appliance cool completely before putting away. Loop cord loosely around appliance when storing.*
- 8. Never yank cord to disconnect from outlet. Instead, grasp just the plug and pull to disconnect.*
- 9. Do not operate appliance with a damaged cord, or if the appliance has been dropped or damaged. To reduce the risk of electric shock, do not disassemble or attempt to repair the appliance. All repairs must be performed by a qualified service professional. Incorrect reassembly or repair could cause a risk of fire, electric shock, or injury when the appliance is used.*
- 10. A loose fit between wall outlet (receptacle) and plug may cause overheating and distortion of the plug. Discontinue use of the product in this outlet. Contact a qualified electrician to replace loose or worn outlets.*
- 11. To reduce the likelihood of circuit overload, do not operate another high wattage appliance on the same circuit.*

-
12. *If an extension cord is absolutely necessary, a 15 amp rated cord should be used. Cords rated for less amperage may overheat. Care should be taken to arrange the cord so that the cord cannot be pulled or tripped over.*

WARNING: *Changes or modifications to this unit not expressly approved by the party responsible for compliance could void the user's authority to operate the equipment.*

FCC CONSUMER ADVISEMENT: *This equipment may generate, use and/or radiate radio frequency energy that may cause harmful interference to radio communications. If this equipment does cause harmful interference to radio or television reception, which can be determined by turning the equipment off and on, the user is encouraged to contact Steamfast Consumer Service at 1-800-711-6617.*

SAVE THESE INSTRUCTIONS

Questions or comments?

- steamfast.com
- consumerservice@steamfast.com
- 1-800-711-6617

Speak your mind! We invite you to review this product online:
steamfast.com/reviews

The following features and accessories are included with your Professional Fabric Steamer. Carefully inspect the packing material for all parts listed below. To obtain possible missing parts, refer to **Product Support** on Page 14 of this manual for Consumer Service contact information.

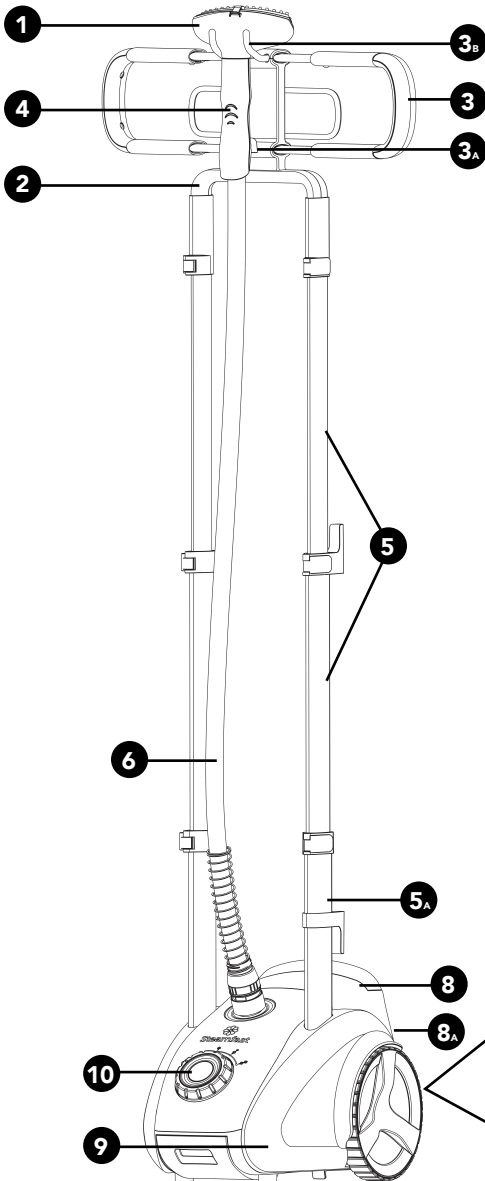

UNIT FEATURES & ACCESSORIES

- 1 Steam Nozzle
- 2 Pole Top
- 3 Hanger
- 3A Hanger Hook
- 3B Steam Nozzle Cradle
- 4 Handle
- 5 Telescopic Pole
- 5A Pole Base
- 6 Hose
- 7 Drain Plug
- 8 Water Tank
- 8A Valve Cap
- 9 Water Reservoir
- 10 Steam Dial
- 11 Fabric Brush

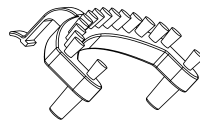

11

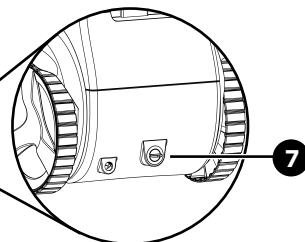

7

-
- The Steam Nozzle (1) emits the flow of hot, penetrating steam produced by the Boiler. The Fabric Brush connects to the Steam Nozzle.
 - The Pole Top (2) connects to the top section of the Telescopic Pole. The Pole Top is comprised of the Steam Nozzle Cradle and Hanger Hook.
 - The Hanger (3) connects to the Pole Top, and is designed to support garments for easy, accessible steaming. The Hanger quickly collapses for convenient storage.
 - The Hanger Hook (3A) supports the included Hanger. The Hanger Hook can alternatively support garments hung from any clean rust-free hanger.
 - The Steam Nozzle Cradle (3B) provides a safe and convenient place to hang the Steam Nozzle when not in use.
 - The Handle (4) is engineered to stay cool while providing maximum grip and comfort.
 - The Telescopic Pole (5) is divided into three sections and can be extended and lowered to a variety of heights for optimal user comfort and convenient storage.
 - The Pole Base (5A) is the receptacle into which the Telescopic Pole is inserted and secured to the top of the main unit.
 - The Hose (6) directs steam flow from the main unit to the Steam Nozzle.
 - The Drain Plug (7) is used for draining water and is the location on the back of the main unit.
 - The Water Tank (8) is the container that holds water to be transferred into the Water Reservoir. The Water Tank is removable for convenient filling, up to a maximum capacity of 106 oz (3,135 ml).
 - The Valve Cap (8A) regulates the flow of water between the Water Tank and the Water Reservoir, and must be removed in order to fill the Water Tank with water.
 - The Water Reservoir (9) holds water before it is transferred to the internal heater and converted into steam.
 - The Steam Dial (10) powers the unit on and off. The Steam Dial also selects the steam level.
 - The Fabric Brush (11) connects to the Steam Nozzle and is designed to brush away particles such as lint, hairs and loose threads.

DOUBLE TELESCOPIC POLES

The Telescopic Pole is made up of three sections:

- TOP (SECTION 1)
- MIDDLE (SECTION 2)
- BOTTOM (SECTION 3)

Sections 1 & 2 are adjustable in length. Section 3 is not adjustable. By using the two extension locks, these sections may be extended or retracted to achieve desired length. Refer to Adjusting Telescopic Poles section below for more details.

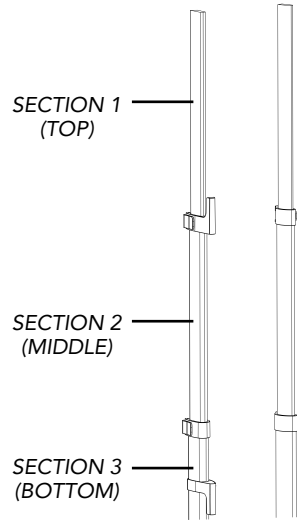

CONNECTING TELESCOPIC POLE

1. Insert telescopic poles into the slots on top of unit ensuring the power cord clips are facing the back of the product toward the Water Tank.

REMOVE TELESCOPIC POLES

1. To remove telescoping poles from unit, push individual levers on bottom of unit to the OPEN position (A). Pull poles out of unit.

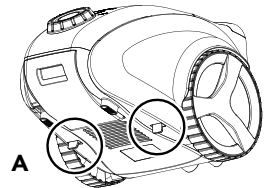

ADJUSTING TELESCOPIC POLES

1. Release extension lock directly below SECTION 1 by swinging hinge outward (B). SECTION 1 can then be extended or retracted.
2. Once SECTION 1 is at desired length, close hinge to once again secure extension lock.
3. Repeat Steps 1 & 2 for remaining hinges.

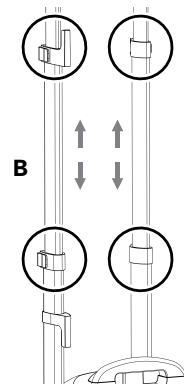

NOTE: It is recommended to extend Telescoping Poles to their full height during steamer operation; this will ensure optimal steam flow through the Hose.

CONNECTING HANGER

1. Release hinges on Hanger.
2. Align Hanger to Telescoping Poles with Nozzle Cradle facing the front of the unit.
3. Insert both ends of the Hanger onto the poles and press both ends simultaneously until the Hanger properly engages (C).
4. Close hinges to secure the Hanger is locked onto the poles.

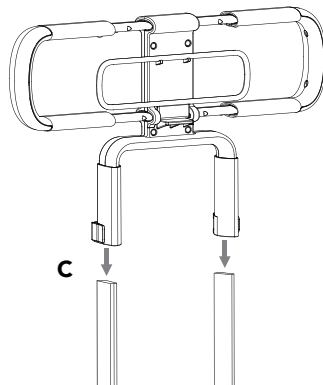

CONNECTING STEAM HOSE

Connect the Steam Hose to the unit by pulling upward on clamping ring on bottom of hose (D). While pulling up, push onto steam outlet on unit (E). Release clamping ring and push down into place.

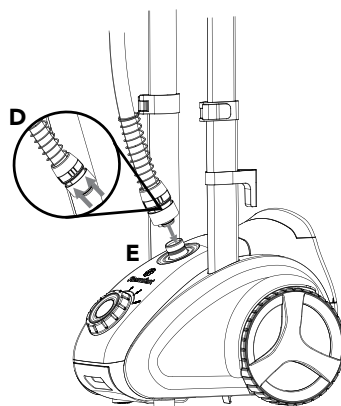

CONNECTING FABRIC BRUSH

1. Make sure Steam Dial is turned to Off position, and that unit is not emitting any steam.

CAUTION: Do not try to connect Fabric Brush while unit is emitting steam, as this can cause burns and injury.

2. Align long pegs on back of Fabric Brush with corresponding slots on face of Steam Nozzle (F).
3. Press Fabric Brush firmly onto Steam Nozzle until it fits snug and firmly into place.

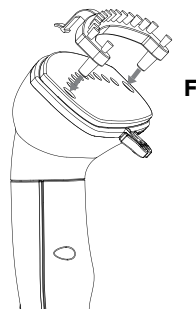

FILLING WITH WATER

1. Remove Water Tank from main unit.
2. Holding Water Tank upside-down, unscrew and remove Valve Cap by rotating it in a counterclockwise direction (G).
3. Fill Water Tank with water through Valve Cap hole. At full capacity, the Water Tank holds 106 oz (3,135 ml) of water, and depending on the steam setting selected, will provide a continuous steam time of 95 min. on High.

NOTE: In order to significantly reduce mineral build-up and prolong the life of your Professional Fabric Steamer, use of distilled or de-mineralized water in the unit is highly recommended. Refer to Page 12 for more information about mineral build-up.

CAUTION: Only water and vinegar should be used in unit – other chemicals or cleaning agents may cause internal damage. If vinegar is used, please be aware that it will create a smell. Do not attempt to substitute any other water tank for the one designed for use with this unit.

4. Replace Valve Cap by rotating it in a clockwise direction.
5. Place Water Tank back onto main unit (H). The sound of water flowing from Water Tank into Water Reservoir should be audible for a short period of time.

NOTE: Water Tank can be removed and refilled at any time during operation – there is no need to turn unit off or allow any cooling period.

IMPORTANT: Do not attempt to operate unit with an empty Water Tank.

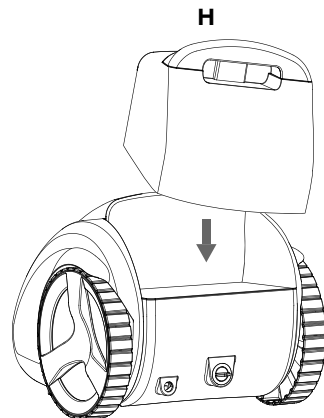
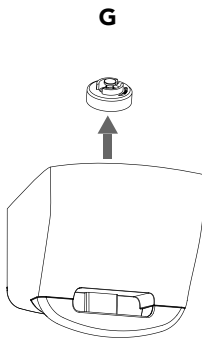

GENERAL OPERATION

NOTE: Be sure that Water Tank has been filled and, if desired, the Fabric Brush is connected before following these steps.

1. For first-time use, remove protective plastic cover that is shipped on electrical plug. Plug power cord into a convenient electrical outlet.
2. Turn Steam Dial to desired steam level. Blue power indicator light will illuminate around Steam Dial (I).

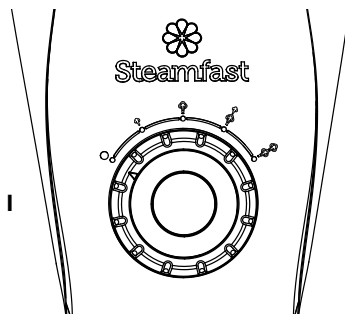

3. After approximately 45 seconds of heating time, unit will begin producing a flow of steam from Steam Nozzle.

NOTE: It is common for the unit to produce gurgling sounds and small amounts of water during the first few minutes of steaming. This is due to water condensation inside cold Hose, and should be reduced as the Hose heats up.

4. Once steam flow is steady and excess condensation has been removed from Hose, you may proceed with your steaming tasks. Refer to Fabric Steaming section on Page 10 for more information about steaming garments and other fabrics.

CAUTION: Always be sure that Steam Nozzle is pointed in a safe direction (away from yourself, other people, pets and plants) when steaming.

5. When you are finished using the Professional Fabric Steamer, immediately turn Steam Dial to "Off" position and unplug power cord from electrical outlet. Refer to Storage and Care on Page 11 for proper cleaning and storage procedures.

FABRIC STEAMING

STEAMING GARMENTS:

1. To extend Hanger, pull on each side to full extension. A garment may now be placed on the Hanger.
2. Alternatively, place garment on a clean, rust-free clothes hanger. Place hanger (with garment) on either hanger hook.

CAUTION: Use care when handling garments hanging on unit. Pulling on the garment with too much force may cause the unit to tip over.

3. Direct Steam Nozzle towards bottom of garment. Steam will rise along inside and outside of fabric, removing wrinkles. Slowly slide Steam Nozzle vertically, from bottom to top of garment.

NOTE: Do not allow kinks to form in Hose at any time during use.

4. Direct Steam Nozzle away from garment and smooth fabric with your free hand.
5. Repeat STEPS 3 & 4 as necessary until fabric is fresh and wrinkle-free.

GENERAL STEAMING TIPS:

- For most effective results, hold Steam Nozzle within 1/2" of fabrics, or press it directly against surfaces. Avoid direct contact to silk.
- Check the fabric care label for manufacturer recommendations. Test the fabric on an unobtrusive area such as an inner seam.
- Test the strength of the color of the fabric on an area of the fabric that is not visible.
- Curtains and draperies can be steamed while still hanging.
- To remove wrinkles from towels, handkerchiefs and napkins, drape them over a rod or towel rack and gently steam them.
- Heavier fabrics may require repeated steaming to achieve desired results.
- To remove exceptionally stubborn wrinkles, steam both sides of fabric.
- Be careful when steaming any delicate fabrics that may be damaged by heat or water spotting.
- To sanitize a fabric, hold Steam Nozzle within 1/2 inch of a single area for at least 5 seconds. Use caution when doing this on more delicate fabrics.
- To remove particles like lint, hairs and threads, connect the Fabric Brush to the Steam Nozzle.
- Certain fabrics are smoothed more easily from the inside.

STEAM SETTING RECOMMENDATIONS

Low ↶	Medium Low ↷
•Silk •Cashmere	•Satin •Velvet •Rayon
Medium High ↶↷	High ↷
•Polyester •Nylon •Jersey	•Cotton •Denim •Wool •Khaki

PROPER STORAGE

Preparing your Professional Fabric Steamer for storage is quick and simple. When you have finished your steaming tasks, follow the steps listed below.

1. Turn Steam Dial to Off position, and unplug power cord from electrical outlet.
2. Allow unit to cool (30 minutes for complete cooling).
3. Bring unit to convenient sink or tub.
4. Remove Water Tank from unit. Unscrew Valve Cap and drain all remaining water from Water Tank. Replace Valve Cap when finished.
5. Open drain plug on back of unit (J) by turning counter-clock wise and drain all remaining water from Water Reservoir. Securely replace Drain Plug and place empty Water Tank back onto main unit.

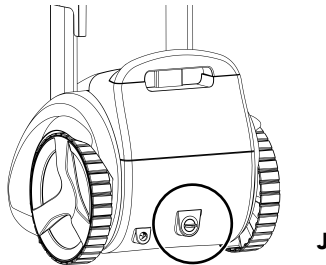

6. For storage convenience, you may wish to collapse the Telescopic Poles to their most compact height.
7. Store Fabric Brush in on-board storage drawer on front of unit (K).
8. Wrap Power Cord around power cord clips on pole (L) and store unit in a cool dry location.

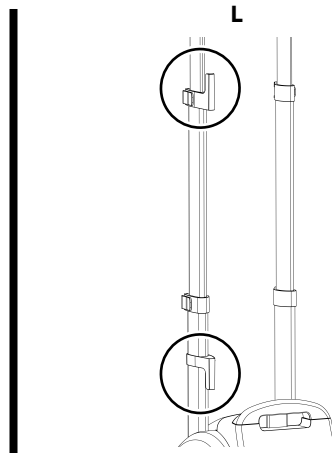
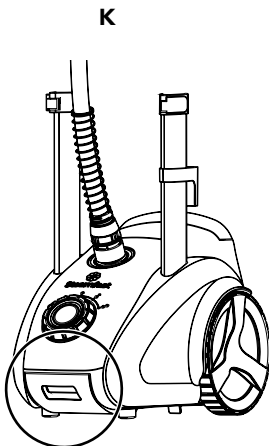

MINERAL BUILD-UP

A common maintenance need for steam appliances is the removal of build-up caused by high mineral content in many municipal water supplies. This mineral build-up may limit the effectiveness and reduce the life of your Professional Fabric Steamer.

The best way to minimize mineral build-up is to use distilled or de-mineralized water when using your Professional Fabric Steamer. In addition, it is recommended that the cleaning procedure below be followed at least once a month in order to remove any deposits that form. This will help to extend the life of your Professional Fabric Steamer and keep it functioning at its maximum potential.

To remove mineral build-up:

1. Turn Steam Dial to "OFF" position and unplug power cord from electrical outlet.
2. Allow unit to cool (30 minutes for complete cooling).
3. Bring unit to a convenient sink or tub.
4. Remove Water Tank from unit. Unscrew Valve Cap and drain all remaining water from Water Tank.
5. Drain all remaining water from the Water Reservoir through Drain Plug.
6. Fill a measuring cup (**not included**) with 12 oz (355 ml) vinegar.
7. Pour vinegar into Water Tank, then replace Valve Cap and place Water Tank back onto main unit.
8. Allow vinegar to flow into Water Reservoir / Boiler and soak for 30-40 minutes.
9. Plug power cord into an electrical outlet and set Steam Dial to "ON" position. Allow unit to steam until no vinegar remains.

CAUTION: Do not allow unit to continue running with an empty water tank.

10. Drain any remaining cleaning solution from the Water Reservoir through Drain Plug.
11. Remove and refill Water Tank to maximum capacity (106 oz / 3,135 ml) with fresh water and place it back onto main unit. Allow all fresh water to flow into Water Reservoir / Boiler and be steamed out. Refill and repeat as necessary until vinegar odor has completely dissipated.
12. When finished, turn Steam Dial to "OFF" position and unplug power cord from electrical outlet.

PROBLEM	POSSIBLE CAUSE	SOLUTION
Unit fails to heat up. When turned, Steam Dial DOES NOT illuminate when set to "ON" position.	Unit is not plugged in.	Plug power cord into electrical outlet.
	Household circuit breaker / ground fault interrupter has tripped or blown a fuse.	Reset circuit breaker / ground fault interrupter, or replace fuse. For assistance, contact a licensed electrician.
	Unit is damaged or otherwise in need of repair.	Immediately cease usage and unplug. Contact Consumer Service for assistance (see below for details).
Unit fails to heat up. When turned, Steam Dial DOES illuminate when set to "ON" position. NOTE: Always allow sufficient time for unit to heat up and begin producing steam.	No water in unit.	Refer to Filling With Water procedure on Page 8 to fill unit with water.
	Mineral build-up in unit.	Refer to Mineral Build-Up section on Page 12 for details.
	Unit is damaged or otherwise in need of repair.	Immediately cease usage and unplug. Contact Consumer Service for assistance (see below for details).
Excessive gurgling in Hose and Steam Nozzle / water drips from Steam Nozzle.	Condensation build-up inside of Steam Nozzle / Hose.	Some gurgling is a natural effect of the steaming process. For excessive gurgling or dripping water, point Steam Nozzle downward and shake thoroughly to remove excess water droplets or extend hose vertically to allow water to drain back into water reservoir. Condensation build-up inside hose may cause excess water to escape from nozzle. To prevent build-up, periodically straighten hose during use.
	Mineral build-up in unit.	Refer to Mineral Build-Up section on Page 12 for details.
Steam output is weak or intermittent.	Water level in Water Reservoir is running low.	Refer to Filling With Water procedure on Page 8 to refill unit with water.
	Mineral build-up in unit.	Refer to Mineral Build-Up section on Page 12 for details.

CONSUMER SERVICES

For problems with your Professional Fabric Steamer, please refer to the troubleshooting guide located above. Additional inquiries should be directed to our consumer support services through our website, www.steamfast.com. If you do not have internet access, you may also contact our Consumer Service Department by telephone, at **1-800-711-6617**.

NOTE: In order for our Consumer Service representatives to help you as quickly and efficiently as possible, please have the following information ready before calling:

- Purchase information (where and when you purchased this product)
- Copy of purchase receipt / proof of purchase
- Product serial number (located near electrical specification label on bottom of unit)

For information regarding your 1 year limited warranty, refer to Page 15 of this manual.

ACCESSORIES & PARTS

When ordering replacement parts and accessories for your Professional Fabric Steamer, you may refer to the part numbers below. Parts and accessories may be ordered through our Web-site:

www.steamfast.com

You may also contact Consumer Service directly:

consumerservice@steamfast.com or **1-800-711-6617**

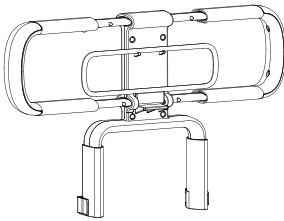

HANGER
A565-001

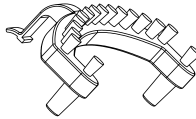

FABRIC BRUSH
A565-002

PRODUCT SPECIFICATIONS

MODEL	SF-565
VOLTAGE	120V~
WATTAGE	1500W
AMPERAGE	12.5A
WATER CAPACITY	106 OZ (3,135 ML)
HEATING TIME	45 SEC (APPROXIMATE)
CONTINUOUS STEAM TIME	95 min HIGH (APPROXIMATE)
UNIT WEIGHT	14.20 LBS. (6.4 KG.)
UNIT DIMENSIONS	15.75" (40.0 CM) x 11.81" (30.0 CM) x 63.39" (161.0 CM)
POWER CORD LENGTH	6' (183.0 CM)

2-YEAR LIMITED WARRANTY

What is covered

Steamfast, a division of Vornado Air, LLC ("Steamfast"). Subject to the terms and conditions of this 2-Year Limited Warranty ("Warranty") as set forth below, Steamfast warrants to the original consumer or purchaser ("Buyer") that this Steamfast®-branded steam product, excluding all accessories and attachments, (the "Product") is to be free from defects in material and workmanship for a period of two (2) years from the date of purchase when used and maintained in accordance with the Owner's Guide (the "Warranty Period"). In the event Buyer notifies Steamfast of a defect in the Product within the Warranty Period, Steamfast will replace the Product and/or defective component parts, as applicable and necessary. Any such replacement will be made at no charge to Buyer for parts or labor, provided that Buyer shall be responsible for all shipping and transportation costs associated with returning the Product to Steamfast for inspection and covered replacement.

What is not covered

This Warranty shall not be applicable to damage or loss caused in whole or in part by:

- Repairs, modifications or alterations to the Product by anyone other than Steamfast.
- Use or operation of the Product outside the permitted or intended uses described by Steamfast in the Owner's Guide, or other careless operation, handling, misuse, or abuse of the Product.
- Lack of proper maintenance or timely cleaning of the Product as specified in the Owner's Guide.
- Use of the Product other than for normal household purposes.
- Normal wear and tear.
- Used consumable parts, accessories and attachments, including, but not limited to, brushes, hangers, scrub pads and mop pads.
- Use of parts and accessories other than those produced or recommended by Steamfast.
- Cosmetic damage, such as scratches, nicks and dents.
- Damage caused by accident, water, flood, fire or other acts of nature or external causes.

Warranty limitations and exclusions

- NO OTHER EXPRESS WARRANTY IS GIVEN BY STEAMFAST TO BUYER AND NO REPRESENTATIVE HAS THE AUTHORITY TO MAKE REPRESENTATIONS OTHER THAN THOSE PROVIDED HEREIN.
- THERE ARE NO WARRANTIES WHICH EXTEND BEYOND THE DESCRIPTION ON THE FACE HEREOF AND ALL IMPLIED WARRANTIES, SPECIFICALLY THE IMPLIED WARRANTIES OF MERCHANTABILITY AND FITNESS FOR A PARTICULAR PURPOSE, ARE HEREBY EXPRESSLY LIMITED TO THE DURATION OF THE WARRANTY PERIOD, UNLESS A SHORTER PERIOD IS PERMITTED BY LAW.
- STEAMFAST'S REPLACEMENT OF THE PRODUCT IS THE EXCLUSIVE REMEDY. UNDER NO CIRCUMSTANCES SHALL STEAMFAST BE LIABLE TO BUYER OR ANY OTHER PERSON FOR ANY INCIDENTAL, SPECIAL, CONSEQUENTIAL, OR OTHER DAMAGES, EVEN IF STEAMFAST HAS BEEN ADVISED OF OR COULD REASONABLY FORESEE THE POSSIBILITY OF SUCH DAMAGES, INCLUDING, BUT NOT LIMITED TO, LOSS OF PROFITS OR DAMAGE, WHETHER ARISING OUT OF BREACH OF WARRANTY, BREACH OF CONTRACT OR UNDER ANY OTHER THEORY OF LAW.
- THIS WARRANTY GIVES BUYER SPECIFIC LEGAL RIGHTS. BUYER MAY ALSO HAVE OTHER RIGHTS WHICH VARY FROM STATE-TO-STATE. SOME STATES DO NOT ALLOW THE EXCLUSION OR LIMITATION OF INCIDENTAL OR CONSEQUENTIAL DAMAGES, AND SOME STATES DO NOT ALLOW LIMITATIONS ON HOW LONG AN IMPLIED WARRANTY LASTS, SO THE ABOVE LIMITATION OR EXCLUSION MAY NOT APPLY TO BUYER.

How do you register the Warranty

Buyer must complete an application to register this Warranty within sixty (60) days following date of purchase. Buyer may either visit Steamfast's website at steamfast.com and complete an online application or mail a completed application to Steamfast. Failure to register this Warranty within sixty (60) days following date of purchase will render this Warranty null and void.

Warranty service

For warranty service, call 1-800-711-6617 or email consumerservice@steamfast.com to obtain a Return Authorization ("RA") form. Include the Product model number and serial number, as well as Buyer's name, address, city, state, zip code and phone number when contacting Steamfast for warranty service. Buyer may be required to provide the original sales receipt for purposes of verifying date of purchase. After receiving the RA form, the Product must be shipped, postage prepaid by Buyer, to:

Steamfast
Attn: Warranty & Repair
415 E. 13th Street
Andover, KS 67002

To assure proper handling, packages must be clearly marked with the RA number. Packages not clearly marked with the RA number may be refused at the receiving dock.

Important: After receiving return authorization, carefully pack the Product to avoid damage in shipping. Damage in shipping is not covered by the Warranty and shall be the sole responsibility of Buyer. Damage or loss not covered by this Warranty or occurring outside the Warranty Period will require a fee to cover the cost of handling and shipping. All such fees and costs shall be the sole responsibility of Buyer.

Please allow at least 1-2 weeks for return of the Product after it is received by Steamfast. For ease of recordkeeping, it is recommended that Buyer staple or attached the original sales receipt to this Owner's Guide and record the Product serial number (located on the Product specifications decal) here:

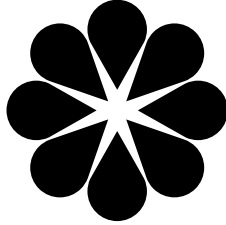

SteamfastTM

Steamfast

415 East 13th, Andover, KS 67002

1-800-711-6617 | steamfast.com | consumerservice@steamfast.com